

STAINLESS STEEL BOOSTER PUMP
MODEL NUMBER CJ90E
1 HP.---SINGLE PHASE---115/230 VOLT

STAINLESS STEEL BOOSTER PUMP
STAINLESS STEEL PUMP HOUSING
PLASTIC IMPELLER, DIFFUSER, & INTERNAL JET ASSEMBLY

IMPORTANT NOTICE---MAXIMUM OPERATING PRESSURE IS NOT TO EXCEED 75 PSI.
INSTALL RELIEF VALVE IN SYSTEM SET TO SO THAT PRESSURE WILL NOT EXCEED
THE MAXIMUM OPERATING PRESSURE OF 75 PSI.

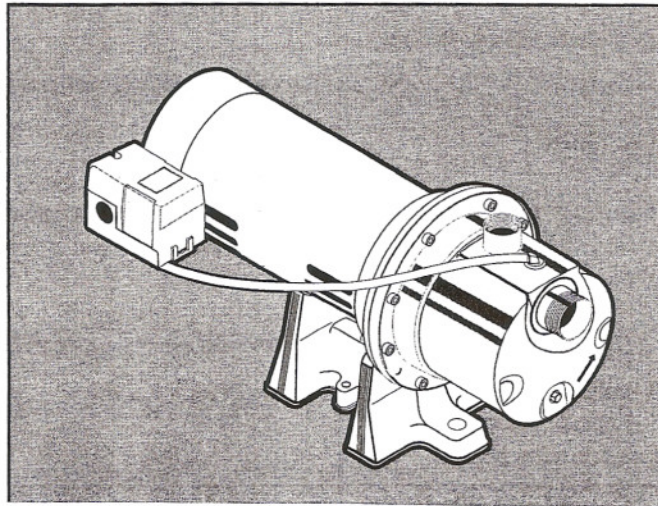

SUCTION LIFT TO 20 FEET

PUMP PERFORMANCE-----CAPACITY SHOWN IN GALLONS PER MINUTE

<u>PUMP #</u>	<u>HP</u>	<u>DISCHARGE</u> <u>PRESSURE</u>	<u>SUCTION LIFT (IN FEET)</u>			
			<u>5'</u>	<u>10'</u>	<u>15'</u>	<u>20'</u>
CJ90E-----1		20 PSI-----	18 GPM----	16 GPM----	14 GPM----	11 GPM
		30 PSI-----	15 GPM----	13 GPM----	12 GPM----	10 GPM
		40 PSI-----	9 GPM-----	7 GPM-----	6 GPM-----	5 GPM
		50 PSI-----	3 GPM-----	2 GPM-----	2 GPM-----	1 GPM

MAXIMUM SHUT OFF PRESSURE AT 0 FEET OF SUCTION LIFT-----65 PSI

<u>PUMP #</u>	<u>HP</u>	<u>SUCTION</u>	<u>DISCHARGE</u>	<u>MOTOR</u> <u>VOLTAGE</u>	<u>APPROX.</u> <u>WEIGHT</u> <u>LBS.</u>
CJ90E-----1		1-1/4"	1"	115/230	33

THIS UNIT IS AVAILABLE ONLY WITH A SINGLE PHASE OPEN DRIP PROOF MOTOR.

STAINLESS STEEL BOOSTER PUMP
MODEL NUMBER CJ90F
1 1/2 HP.---SINGLE PHASE---115/230 VOLT

STAINLESS STEEL BOOSTER PUMP
STAINLESS STEEL PUMP HOUSING
PLASTIC IMPELLER, DIFFUSER, & INTERNAL JET ASSEMBLY

IMPORTANT NOTICE---MAXIMUM OPERATING PRESSURE IS NOT TO EXCEED 75 PS
INSTALL RELIEF VALVE IN SYSTEM SET SO THAT PRESSURE WILL NOT EXCEED
THE MAXIMUM OPERATING PRESSURE OF 75 PSI.

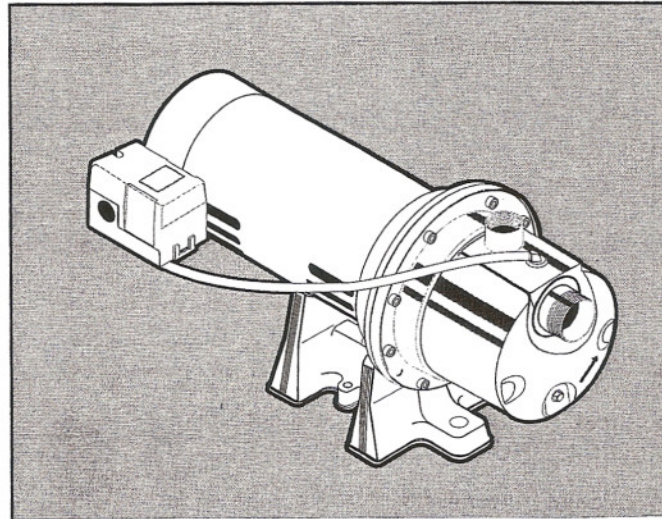

SUCTION LIFT TO 20 FEET

PUMP PERFORMANCE-----CAPACITY SHOWN IN GALLONS PER MINUTE

PUMP #	HP	DISCHARGE PRESSURE	SUCTION LIFT (IN FEET)			
			5'	10'	15'	20'
CJ90F-----1-1/2		20 PSI-----	18 GPM----	16 GPM----	14 GPM----	12 GPM----
		30 PSI-----	18 GPM----	16 GPM----	14 GPM----	12 GPM----
		40 PSI-----	18 GPM----	16 GPM----	14 GPM----	11 GPM----
		50 PSI-----	14 GPM----	12 GPM----	10 GPM----	9 GPM----

MAXIMUM SHUT OFF PRESSURE AT 0 FEET OF SUCTION LIFT-----80 PSI.

PUMP #	HP	SUCTION	DISCHARGE	MOTOR VOLTAGE	APPROX. WEIGHT LBS.
CJ90F-----	1-1/2	1-1/4"	1"	115/230	36

THIS UNIT IS AVAILABLE ONLY WITH A SINGLE PHASE OPEN DRIP PROOF MOTOR.